

CUSTOMER SUPPORT

INDONESIA

PT. RIGEL MARKETING INDONESIA | OFFICE & SHOWROOM

Jl. Sultan Iskandar Muda No. 99B, Arteri Pondok Indah, Gandaria Jakarta Selatan 12240, Indonesia

Tel : (62) 21 2277 1188
Fax : (62) 21 2277 1199
E-mail : sales.id@rigel-group.com
Website : www.rigel.com.sg

VIETNAM

RIGEL TECHNOLOGY (INDOCHINA) LLC | OFFICE & SHOWROOM

Unit 1501A, Centre Point Building, 106 Nguyen Van Troi Street, Ward 8, Phu Nhuan District, Ho Chi Minh City, Vietnam

Tel : (84) 28 3600 3700
Fax : (84) 28 6257 3939
E-mail : sales.vn@rigel-group.com
Website : www.rigel.com.cn

CHINA OFFICES & FACTORIES 工厂:

NINGBO RIGEL BATHROOM MARKETING CO., LTD (宁波锐佳卫浴销售有限责任公司)

No.11th, Meishan Avenue Business Centre, Room Nos. 3726, Beilun District, 315832, Zhejiang, China

Tel : (86) 574 5626 1876
Fax : (86) 574 5626 1588
E-mail : sales@rigel-group.com
Website : www.rigel.com.cn

RIGEL TECHNOLOGY CERAMICS (SICHUAN) CO., LTD | 锐佳科技陶瓷工业(四川)有限公司

No. 18, Shuanghechang, Anfu Town, Naxi District, 646300 Luzhou City 3 Sichuan, China

Tel : (86) 830 4270 028
Fax : (86) 830 4270 636
E-mail : sales@rigel-group.com
Website : www.rigel.com.cn

RIGEL TECHNOLOGY (NINGBO) CO., LTD | 锐佳科技(宁波)有限公司

No. 6, Chuangye Road 3, Ningbo Beilun Free Trade West Zone, 315800 Ningbo, Zhejiang China

Tel : (86) 574 5626 1688
Fax : (86)574 5626 1588
E-mail : sales@rigel-group.com
Website : www.rigel.com.cn

RIGEL®

INSTRUCTION MANUAL

RL-ASD103WN

WALL MOUNTED AUTO SOAP DISPENSER

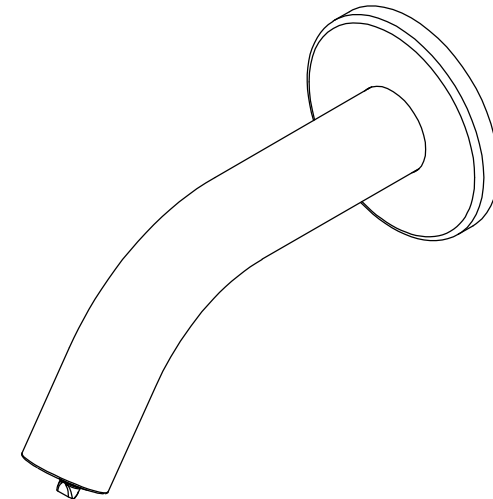

IMPORTANT SAFETY INFORMATION

The instructions contained herein are for the safe and correct use, care and maintenance of the product, to minimize the risk of injury and damage to yourself, other persons, or property.

Please read the following safety information thoroughly and retain this document for future use and reference.



WARNING

Instructions accompanied by this symbol could lead to death or serious injury if they are ignored or followed improperly.

IMPORTANT SAFETY, INSTALLATION AND OPERATING INSTRUCTIONS

Please read this manual and ensure that you understand the instructions and procedures stated within before installing or operating the product.



WARNING

Dangerous Voltage Inside
Do not expose the unit to rain or moisture to prevent shock and fire hazard.

Rigel products have been designed and tested to be safe and risk-free when installed, operated and maintained in good working order, in accordance with the instructions and recommendations found in this document.

There are no user-serviceable parts in this product. Please contact a qualified and licensed trades person should the product require dismantling and/or repairs.

Supervision should be given to any persons who may have difficulty understanding or operating the controls of the product. Extra consideration should be given to the young, infirm, elderly, or any person inexperienced in the correct operation of the product's controls.

Regular cleaning of the sensor eyes is recommended to remove dirt and stains which may impede the sensor's functionality.

DISCLAIMER

While every effort has been made to ensure that the information contained within this document was accurate and complete at the time of printing, Rigel Technology (S) Pte Ltd shall not be held responsible for any errors, omissions or inaccuracies. By installing or using the product, the user agrees that no responsibility for the consequences resulting from any misinformation shall be incurred on Rigel Technology (S) Pte Ltd. Rigel Technology (S) Pte Ltd reserves the right to change the specifications and functions of the product described herein at any time without prior notice.

No part of this guide may be reproduced, stored in a retrieval system, or trans-mitted, in any form or by any means, electronic, mechanical, recording, or otherwise, without the prior written permission of Rigel Technology (S) Pte Ltd.

CUSTOMER SUPPORT

AFTER SALES SERVICE

Rigel's Customer Support Team can provide you with service visits, sale of spare parts, and general product help and advise.

SPARE PARTS

Spare parts for all Rigel products are available for up to 10 years after the product's date of final manufacture. You should only purchase spare parts directly from our Customer Support Department, or from Rigel's approved stockists or merchants to ensure authenticity and to maintain validity of your warranty.

NOTE: As a safety precaution, spare parts that require exposure to voltage from the power grid mains will only be sent to qualified personnel.

SERVICE GUARANTEE

All servicing provided by Rigel will be performed by a trained technician or agent, with genuine spare parts, and will come with a 6-month warranty on the repair. Servicing outside of the product's warranty will be charged at a reasonable cost.

CONTACT US

SINGAPORE

RIGEL TECHNOLOGY (S) PTE LTD | HEADQUARTERS

Rigel Innovation Centre No. 20 Changi Business Park Central 2 Singapore 486031

Tel : (65) 6812 6288
Fax : (65) 6812 6388
E-mail : sales@rigel-group.com
Website : www.rigel.com.sg

MALAYSIA

RIGEL TECHNOLOGY (M) SDN BHD | OFFICE & SHOWROOM

Wisma Rigel, No 16 & 18, Jalan 3/33B, MWE Commercial Park, 6 ½ Miles, Off Jalan Kepong, 52000 Kuala Lumpur, Malaysia

Tel : (603) 6258 6016
Fax : (603) 6258 5498
E-mail : sales.my@rigel-group.com
Website : www.rigel.com.my

WARRANTY

Please read the following warranty information thoroughly and retain this document for future use and reference.

Rigel Technology (S) Pte Ltd ("Rigel") warrants the products against any defect of materials or workmanship for a period of 1 year from the date of purchase.

Within the warranty period, all defective parts will be repaired and/or replaced free of charge.

To be eligible for free repair and/or replacement, any service work on the product must be undertaken by Rigel or our approved agents.

Service under this warranty will not affect the warranty expiry date, and any warranty on exchanged parts or products will end when the warranty expires.

This warranty is only applicable for products properly installed and operated in accordance to the operating procedures stated in the instruction manual.

This warranty does not extend to washroom accessories or other peripheral items.

Rigel's responsibility under this warranty does not apply to damage/defects caused by:

- Misuse, negligence, or accidents.
- Public abuse or vandalism.
- Repairs or alterations not authorized by or performed without consultation from Rigel.
- Repairs or alterations that do not comply with Rigel's installation instruction.
- Repairs or alterations that were not performed with genuine parts supplied by Rigel.

Rigel will not be held liable for any incidental or consequential damages, including loss of profits or savings, arising from the use or misuse of the products.

The terms in this warranty are only valid after:

- Full payment has been made.
- The official Warranty Card is completely and correctly filled out in ink and returned to Rigel within 14 days of purchase. Loss or misplacement of the Warranty Card, or unauthorized amendments to the Warranty Card, shall render the warranty null and void.

This warranty is in addition to your statutory and other legal rights.

ELECTRICAL INSTALLATION REQUIREMENTS

- 1) The installation must comply with the "Requirements for Electrical Installation" commonly referred to as the IEE Wiring Regulations, or any particular regulations and practices, specified by the local electricity supply company in force at the time of installation.
- 2) In accordance with the current edition of "The Plugs and Sockets etc (Safety) Regulations" in force at the time of installation, the appliance is intended to be permanently connected to the fixed wiring of the electrical mains system.
- 3) In domestic installation, the rating of the electricity supply company fuse and the consumer unit must be adequate for the additional demand required for the unit. As this is a high powered unit, it is essential to contact your electricity supply company to ensure that the existing supply is adequate for the additional load. Voltage drop due to high local demand will reduce the product performance.
- 4) The unit **must be earthed** by connecting the supply cable earth conductor to the earth terminal. Within the washroom, all accessible conductive parts of electrical equipment and extraneous conductive (metal) parts that are likely to introduce earth potential, must be electrically bonded to earth using a minimum 4mm² cable if unprotected and 2.5mm² cable if protected.
- 5) To obtain full advantage of the performance from the unit, it is advisable to have the shortest possible route for the cable from the consumer unit to the product. Long cable runs will increase the voltage drop and affect the performance of the unit. The maximum permissible length is dependent upon current demand, voltage drop and cable size, refer to IEE Wiring regulations for further information.
- 6) The current rating to the cable will be reduced if it is bunched with other cables, surrounded by thermal loft or wall insulation or placed in areas where the ambient temperature exceeds 30°. Under these conditions, de-rating factors apply and it is necessary to select a larger cable size.
- 7) In the majority of installations, one or more of the above conditions will apply and it is recommended that a 10mm² cable be installed. The minimum recommended cable size in ideal conditions is 6mm².
- 8) A separate, permanently connected supply must be taken from the consumer unit through a double pole switch, which has at least 3mm minimum contact gap. The switch may be a ceiling mounted pull cord type within the washroom or a wall mounted switch in an adjacent room.
- 9) A 30mA residual current device (RCD) must be fitted. This may be a part of the consumer unit or a separate unit.
- 10) The product circuit must be protected by either a miniature circuit breaker (MCB) or cartridge fuse of rating 10 amps installed at the Consumer Unit or Fuse Board.
- 11) When installing the cable, individual cores must not be twisted before entering the terminal block. Care should be taken that no strains are exerted on the terminal block when connected to the cable cores. Ensure all connections are tight to prevent overheating.
- 12) Do not turn on the electrical supply until the installation is complete and the unit is ready to be operated.

PART LIST & ILLUSTRATIONS

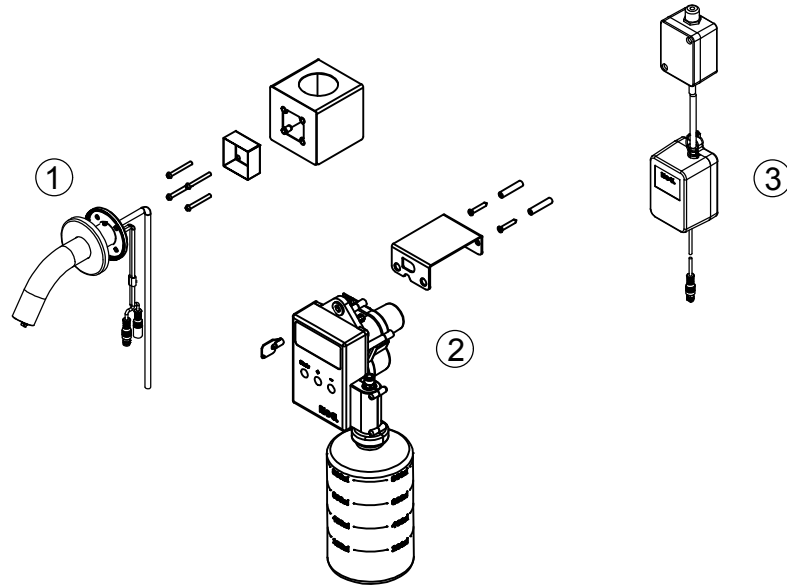

NO.	PART NO.	DESCRIPTION	QTY
①	SA-SPTASD103WN	SPOUT ASSEMBLY	1SET
②	SA-ASD200DE-900_1 & ASD200D-BOTTLE	CONTROLLER ASSEMBLY & SOAP BOTTLE	1SET
③	SA-PS18V-IS	POWER SUPPLY	1

RC1000e REMOTE CONTROL

OPERATING PROCEDURE FOR SD

1. The remote control can be used to adjust the sensing distance of the sensor faucet.
2. The remote control should be pointed to the nozzle of the Sensor Faucet during the adjustment, be cautious not to get too close to the nozzle to avoid activation of the Sensor Faucet. A short 'beep' will be heard when a successful adjustment is made. A double 'beep beep' will be heard when the setting is being adjusted to minimum or maximum.
3. The steps for adjustment are summarized as followed:

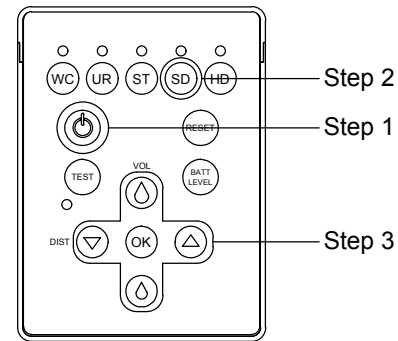

Step 1: Press the power button to switch on the remote control.

Step 2: Press the 'SD' button to select Auto Soap Dispenser mode.

Step 3: Press UP or Down to adjust soap volume.

: Press LEFT or RIGHT to adjust sensor sensing distance.

Press OK when done adjusting.

TROUBLE SHOOTING GUIDE

OUT-OF-BOX FAILURE

If the product does not function as specified or reasonably expected upon first use after installation, please contact your contractor or trades person to check if the installation and commissioning are performed satisfactorily and in accordance with the instructions in the Installation Manual. You or your installer may contact Rigel for any advise and we will be glad to be of assistance. Should this still not resolve the issue, please contact our Customer Support Department and we will arrange for a visit by a Rigel service technician if necessary.

PERFORMANCE DECLINE

If the product is exhibiting a noticeable decline in performance after substantial use, please refer to the Product Care and Cleaning section of this Manual to check if simple home maintenance is required. Should product performance not improve after simple home maintenance is performed as per the instructions in the Product Care and Cleaning section, please contact our Customer Support Department to discuss the issue you are facing, and to request for service under warranty if applicable.

RC1000e REMOTE CONTROL

OPERATING PROCEDURE FOR SD

*Note : Remote control not included, sold separately.

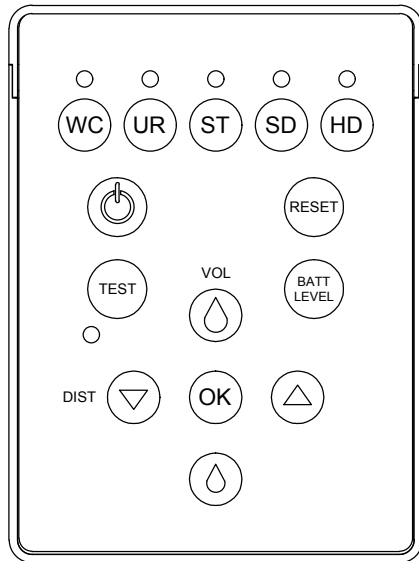

Press the power button to switch 'on' the remote control.



*Point the remote control to the 'sensor eye' before pressing command button listed below.

Press 'SD' to select soap dispenser mode.



Long press to re-calibrate the sensing distance according to default setting.

Press to test the dispensing function once.



Decrease sensor sensing distance.



Increase sensor sensing distance.



Soap dispenser - Increase the volume of soap.

Foam soap dispenser - Increase the volume of air.



Soap dispenser - Decrease the volume of soap.

Foam soap dispenser - Decrease the volume of air.



Press 'OK' to save the settings

PRODUCT DIMENSIONS & INSTALLATION DIAGRAM

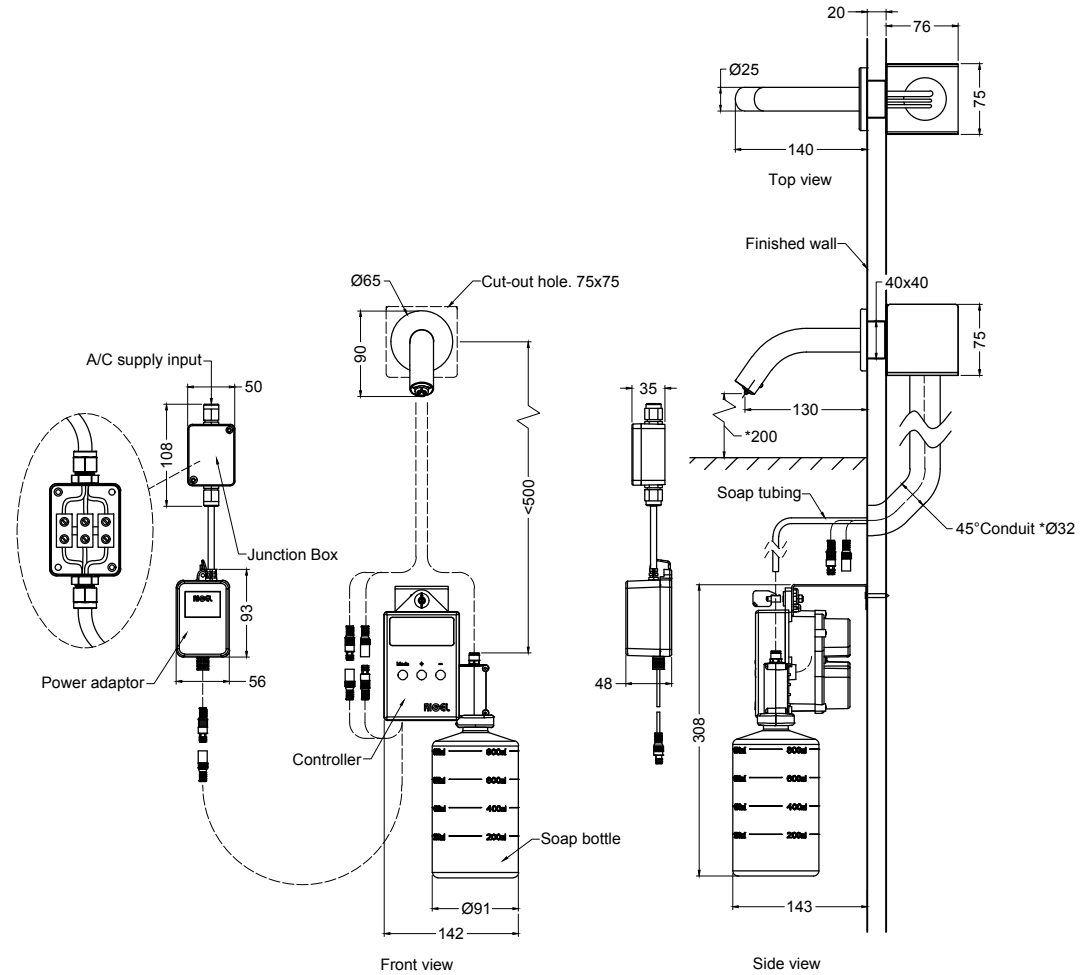

INSTALLATION GUIDE

1.

Refer to pg.4 for opening hole dimensions.

Insert the casing into the uncemented brick wall, ensuring the casing is flush into the wall and the position is upright.

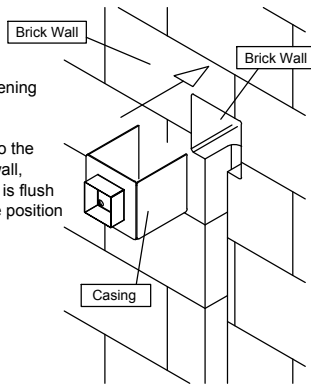

2.

Apply tiles or granite to cover the brick wall outside the template.

Note:
Tiling thickness must not be shallower than the top rim of the template cover provided.

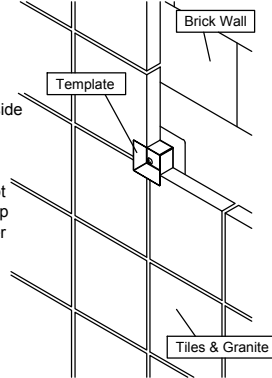

3.

Remove the template from the casing.

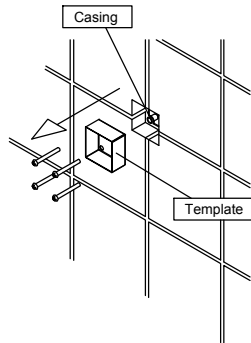

4.

Insert the sensor cable & tubing into the conduit.
Mount the spout onto the casing and fasten the spout by using the set screw.

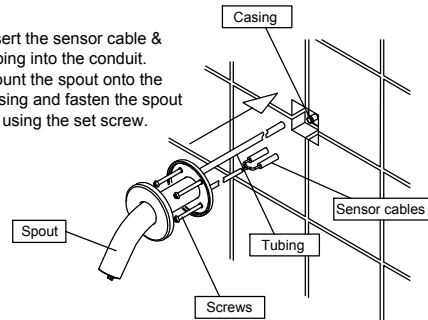

5.

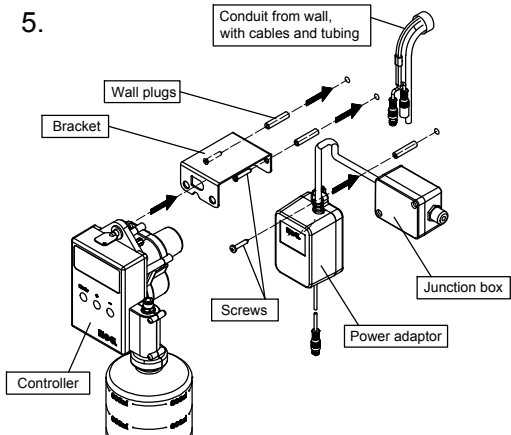

Drill the mounting holes on finished wall to accommodate the mounting screw, mounting bracket & power supply.

Note:
Improper connection may damage the product.
Connect the cables according to the diagram shown in pg 4.
Ensure the cables & hose are connected to corresponding slot.

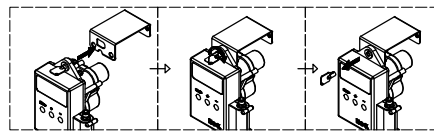

Mount the controller onto the bracket as shown.

PRODUCT SPECIFICATIONS

Dimensions (faucet)	140(L) x Ø65(W) x 90(H)mm
Material (faucet)	Brass
Finishing (faucet)	Chrome
Power input	220-240V AC 50/60Hz
Sensing range	100mm (default)
Soap viscosity	<1500 cPs (recommended)
Discharge volume	0.5ml approx. / per dosage
Discharge soap state	Liquid
Soap bottle capacity	800ml (0.8Litres)